

Quarter Glass

Removal

NOTE: To remove the quarter glass, first remove the quarter window trim panel and quarter trim panel (page 14-44).

1. Remove the quarter window trim.

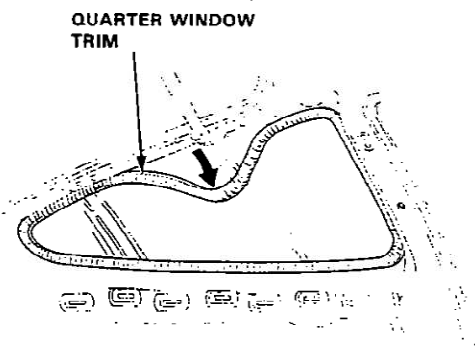

2. From inside the car, use a knife to cut through the glass adhesive all the way around.

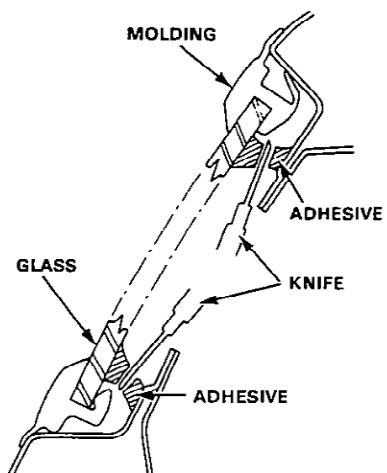

3. As an assembly, pry the glass and upper and front moldings away from the car at the clip points shown.

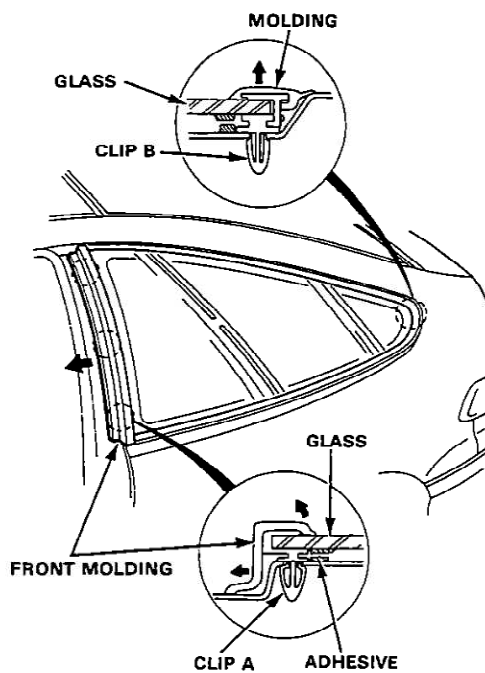

4. Remove the quarter glass molding if the glass is to be reused.



Installation

1. Scrape the old adhesive smooth with a knife, to a thickness of about 2 mm (0.08 in.) on the bonding surface around the entire glass flange.

NOTE:

- Do not scrape down to the painted surface of the body; damaged paint will interfere with proper bonding.
- Remove all traces of the rubber spacer material from the body.
- Mask off surrounding surfaces before applying primer.

2. Clean the body bonding surface with a sponge dampened in alcohol.

NOTE: After cleaning, keep oil, grease or water from getting on the surface.

3. If the glass is to be reinstalled, use a putty knife to scrape off all traces of old adhesive, then clean the glass surface with alcohol where new adhesive is to be applied.

NOTE: Make sure the bonding surface is kept free of water, oil and grease.

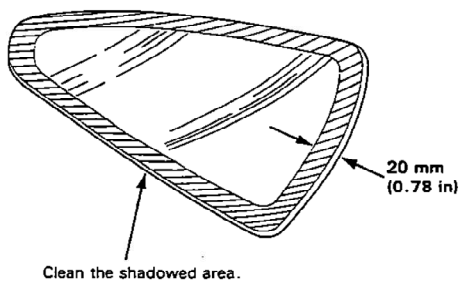

4. Attach the front molding and 3 clips to the front edge of the quarter glass as shown.

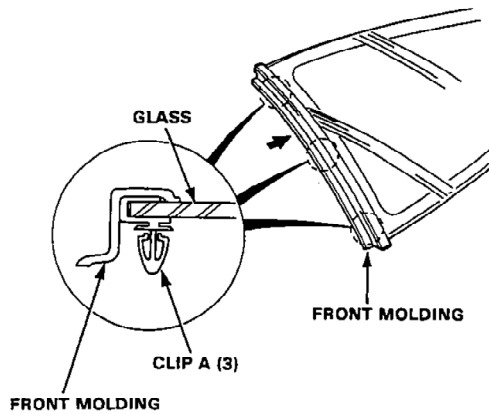

5. Install the quarter molding on the glass by using the clips shown.

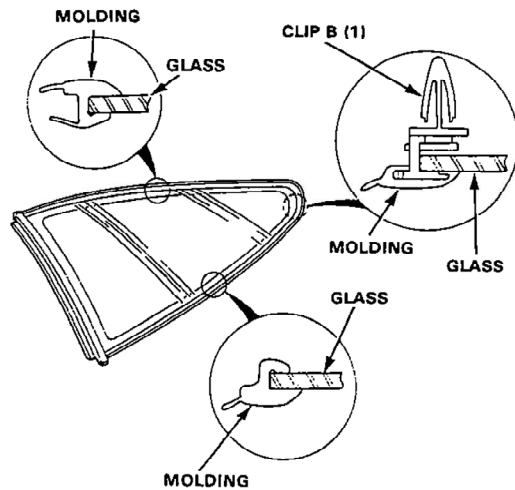

(cont'd)

Quarter Glass

Installation (cont'd)

6. With a sponge, apply a light coat of glass primer around the edge of the glass as shown, then lightly wipe it off with gauze or cheesecloth.

NOTE:

- Do not apply body primer to the glass, and do not get body and glass primer sponges mixed up.
- Never touch the primed surfaces with your hands. If you do, the adhesive may not bond to the glass properly, causing a leak after the glass is installed.
- Keep water, dust, and abrasive materials away from the primed surface.

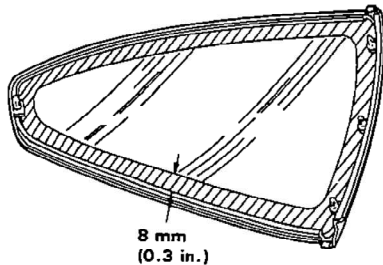

7. Install the quarter window trim.

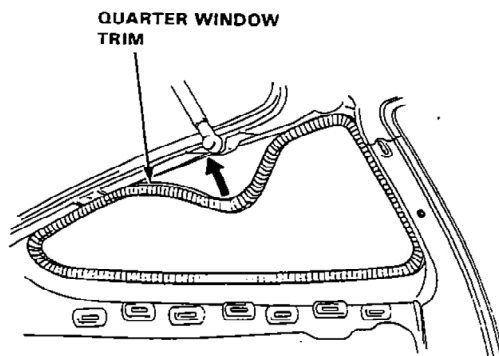

8. With a sponge, apply a light coat of body primer to the original adhesive remaining around the window opening flange.

NOTE:

- Do not apply glass primer to the body, and be careful not to mix up glass and body primer sponges.
- Never touch the primed surfaces with your hands.

QUARTER WINDOW TRIM

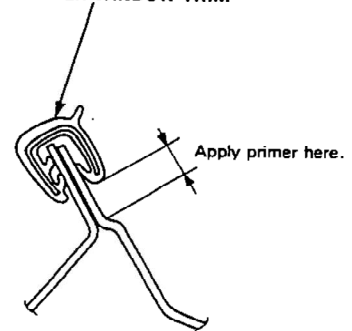

9. Thoroughly mix the adhesive and hardener together on a glass or metal plate with a putty knife.

NOTE:

- Clean the plate with a sponge and alcohol before mixing.
- Follow the instructions that come with the adhesive.

10. Before filling a cartridge, cut off the end of the nozzle at the angle shown.

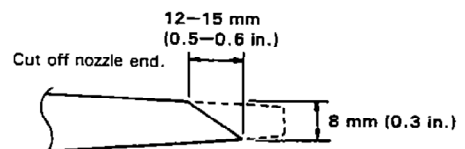



11. Pack adhesive into the cartridge without air pockets, to ensure continuous delivery. Put the cartridge in a caulking gun, and run a bead of adhesive around the edge of the glass as shown.

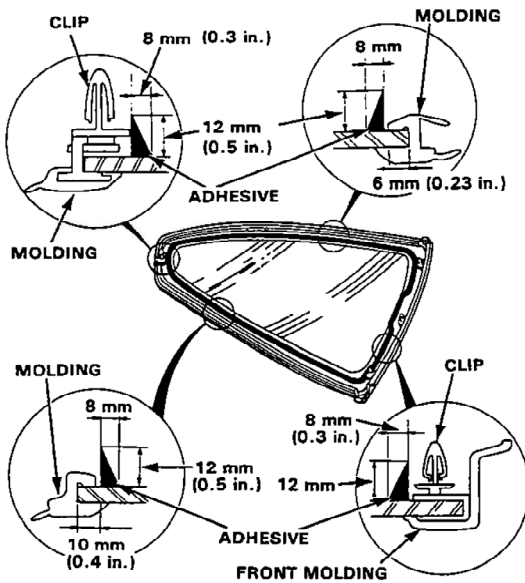

12. Use suction cups to hold the glass, then set it on the adhesive. Lightly push on the glass until its edges are fully seated on the adhesive all the way around.

NOTE: Do not open or close the doors and tailgate until the adhesive is dry.

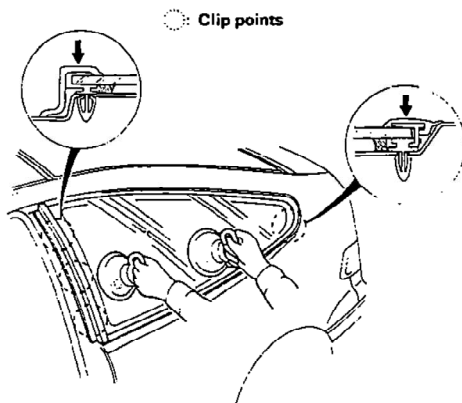

13. Scrape or wipe the excess adhesive off with a putty knife or gauze.

NOTE: Use a shop towel dampened with alcohol or unleaded gasoline to remove adhesive from a painted surface or glass.

14. After the adhesive is dry, spray water over the glass and check for leaks. Mark leaking areas and let the glass dry, then seal with sealant.

NOTE: Let the car stand for at least 4 hours after glass installation. If the car has to be used within the first 4 hours, it must be driven slowly.

15. Reinstall all remaining removed parts.